

# New design concepts for strengthening continuous reinforced-concrete beams

T N Azizov<sup>1</sup>, D V Kochkarev<sup>2</sup> and T A Galinska<sup>3,4</sup>

<sup>1</sup> Technical and Technological Disciplines, Labor Safety and Life Safety Department, Pavlo Tychyna Uman State Pedagogical University, Sadova St.2, 20300 Uman, Ukraine

<sup>2</sup> Urban Construction and Economy Department, National University of Water and Environmental Engineering, Soborna St.11, 33028 Rivne, Ukraine

<sup>3</sup> Architecture and Urban Construction Department, Poltava National Technical Yuri Kondratyuk University, Pershotravnevyi av. 24, 36011 Poltava, Ukraine

<sup>4</sup>Email: galinska@i.ua

**Abstract.** The present article is concerned with basic methods of reinforcement of continuous reinforced-concrete beam constructions. The main disadvantages and difficulties in strengthening such load carrying structures have been identified in this academic paper. There has been offered the method of reinforcement of continuous reinforced-concrete beam constructions. Besides, the authors have established the procedure of designing effective continuous reinforced-concrete beams in case of the reinforcement. The basic principle of enforcement of continuous reinforced-concrete beams is proposed in this exploratory development. This principle lies in the fact that it is necessary to find the desired span stiffness of continuous reinforced-concrete beam constructions, which would provide sufficient reinforcement in the reference section of the beams. In this case, there is no need to strengthen reference sections, which is practically impossible to do in most instances without dismantlement of the existing concrete floor slabs. For reinforcement systems designing, it is proposed to use the method of design resistance of reinforced concrete, which uses theoretically, and experimentally confirmed prerequisites and hypotheses. The calculations are made by the iteration method. There has been provided a calculation example of enforcement of continuous reinforced-concrete beam constructions using the proposed method.

## 1. Distinctive features of reinforcement of statically indeterminate continuous reinforced-concrete beams with quadrangular section

Modern development of technologies causes frequent changes in the parameters of space-planning decisions for buildings and structures. In most cases, this necessitates not only the change in space-planning solutions of the buildings, but also leads to an increase in load on the main load carrying structures.

In general, all methods of strengthening of reinforced-concrete beam structures can be divided into two basic techniques [1]: reinforcement by increasing the size of the cross-section and by changing the design model. According to architectural and space-planning designs, priority should be given to the first method, since the change in the design model, in most cases, leads to significant deterioration of space-planning solutions of buildings, due to the presence of secondary members - subdivided panels, discharge frames or beam knees and bracing beams [1].

Reinforcement of continuous reinforced concrete beams with the help of building-up is usually performed in such a way that both the beam seat zone and the beam span are strengthened. This is due to the fact that with increment of load, both the moment of a support and the beam span moment increase (Fig. 1). Notwithstanding, an increase in the cross section of the beam above the beam seat, as a rule, causes difficulties, which sometimes can become insuperable. It is related to the fact that it is very difficult to connect two adjacent parts of a continuous beam on a beam seat (or on a column, on the main beam of a one-way ribbed floor, etc.). And in case of monolith flooring with the main and secondary beams, it becomes practically impossible to strengthen the secondary beam at the point of its adjoining to the main beam. In the case of strengthening above the column, literature generally offers fastening to columns [1, 2, 3]. On top of that, when reinforcing the beam seat zone, it becomes necessary to knock down the floor systems. All of these things not only complicate the execution of work, but also raise the price of reconstruction.

It might be interesting to consider the possibility of reinforcing continuous reinforced-concrete beams in such a way that it would be possible to give a wide berth to the reinforcement of the beam seat zone, and solely focus on reinforcing just the beam span. However, this brings up the question of the calculation procedure for such a beam, in which both the support and the beam span moment increase, but only the beam span is strengthened. In accordance with the abovementioned, the purpose of this article is to propose strengthening of continuous reinforced-concrete beams while under reconstruction by increasing the cross section only in the beam span, as well as developing the calculation procedure for such beams.

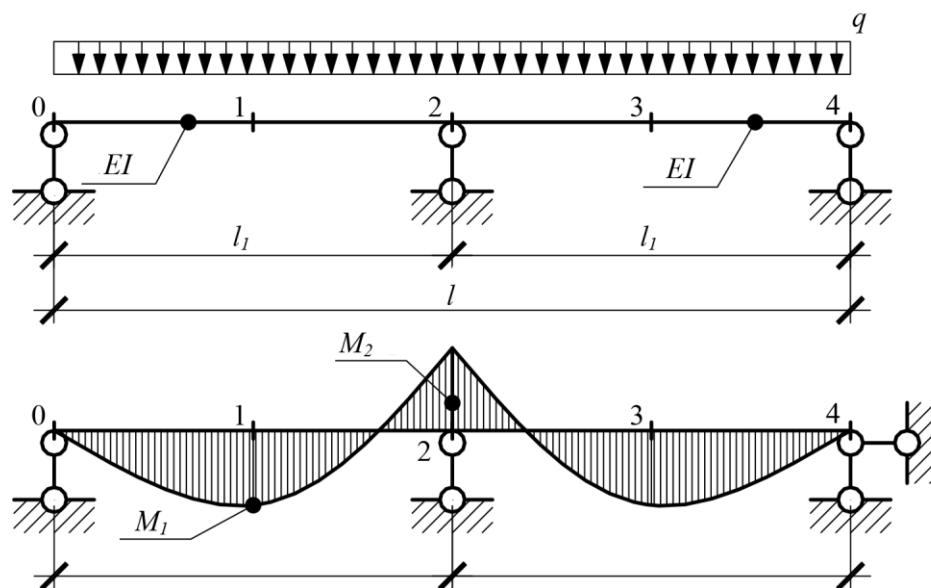

Figure 1. Bending moment curves in a continuous beam.

## 2. Fundamentals of design of statically indeterminate continuous beams with quadrangular section in case of strengthening of the beam span part only

As explained earlier, the greatest difficulty is the strengthening of the upper zone of continuous beams when they are being strengthened. Consequently, it would be desirable to consider such a design model in which the bending moment at support would remain constant before and after reinforcement. This is illustrated in Fig. 2, a full line graph shows the bending moment curve from uniform distributed load up to the moment of reinforcement. The dotted graph shows the bending moment curve from uniform distributed load after the process of reinforcement. Scilicet, the task of finding an effective solution to the strengthened beam resolves itself into finding some rigidity of its beam span part. This rigidity must be such that, as a result of the static analysis, moments at support in the strengthened beam would correspond to the moments before the reinforcement.

Due to the fact that reinforced concrete is elastoplastic material that works with cracks, the rigidity of reinforced concrete beams is non-linear. Modern design methods for reinforced concrete elements both at bending and bending combined with torsion in all cases take into account changes in their stiffness from crack formation and nonlinear work of concrete [4, 5, 6, 7, 8]. The account of nonlinear work significantly complicates the static analysis of both reinforced concrete constructions in general and relevant beams in particular.

The following design procedure for the reinforcement of continuous beams is proposed:

1. Let us find the maximum beam moment, which can take up the cross-section of the existing continuous reinforced-concrete beam before the reinforcement.
2. At the elastic stage, it is necessary to correlate the ratio of the beam span stiffness and beam seat stiffness in the continuous beam. At this stage, the influence of reinforcement should be neglected. The stiffness values have to be set in such a way that with the increase in load the moment at support would not grow, but only the beam span moment would amplify. It is simply done by the method of structural analysis as it is known that with the increase in the stiffness of any section of a statically indeterminate structure, the bending beam moment in this section scales up. Therefore, by stiffening the beam span, the beam moment can be increased and thus it is not difficult to come up to the situation when the bending moment in the beam span becomes greater than the support moment.
3. Let us ad interim set-up the cross-sectional dimensions of the beam span, from the obtained ratios by elastic analysis.

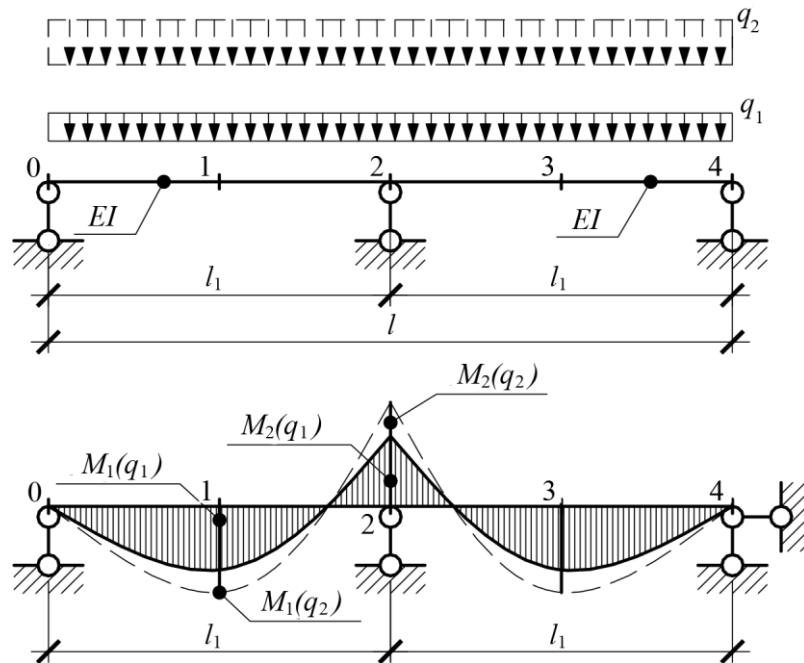

**Figure 2.** On the question of searching an effective design concept of the continuous beam.

4. Let us perform nonlinear calculation taking into account elastoplastic properties of materials and revise the value of the bending moment curve. We offer to perform this calculation by the method of design resistance of reinforced concrete, taking into account nonlinear deformation curves [9, 10, 11]. As is known, in this method engineering stresses, which are tabulated by critical parameters, occur as the main variable characterizing the load level, h.e.

$$\sigma_{zM} = M/W_c = f(\Sigma\varepsilon, \rho_f, C, f_y). \quad (1)$$

In expression (1):  $M$  is the bending beam moment in the corresponding section, kN·m;  $\Sigma\varepsilon$  – total deformations of the most compressive zone of the concrete and tensile reinforcement  $\varepsilon_c + \varepsilon_s$ ;  $C$  –

concrete grade, this concrete grade is characterized by the parameters of the deformation curve under tension and compression, that is  $E_c, \varepsilon_{c1}, \varepsilon_{cu}, f_c, \varepsilon_{ct1}, \varepsilon_{ctw}, \rho_f$  – percentage of reinforcement of cross section of the element by longitudinal reinforcement  $\rho_f = A_s / (bd) \cdot 100\%$ ;  $W_c$  – section modulus of the working section of concrete  $W_c = bd^2 / 6$ ,  $f_y$  – yield point of reinforcement.

Another difficulty in designing reinforcement of continuous reinforced-concrete beams is that their strengthened part can be made of another concrete grade. As a rule, the concrete grade for reinforcement is higher than the concrete grade of the existing beams. This creates additional difficulties in determining the stiffness of the reinforcement beams. The calculation of such composite beams can be performed according to the method. However, non disposable iterations should be used for this purpose. In order to avoid such a situation, we offer the following calculation procedure by means of the design resistance method.

In this case, it is assumed that the reinforcement of the beam will be done by increasing the width of the section. Then at the initial stage, we will establish the necessary beam stiffness from one concrete grade. Then we will sort out additional elements from another concrete grade, provided that the same bending beam moment is taken up by the combined cross-section of the element. This method assumes the absence of offset between old and new reinforcement concrete. For this purpose, it is convenient to use the modified method of design resistance of reinforced concrete [9, 10, 11]. The main parameter, which used in this method, is the mechanical percentage of reinforcement

$$\omega = \frac{\rho_f f_{yd}}{f_{cd}}, \quad (2)$$

where  $\rho_f$  – percentage of reinforcement of cross-section with longitudinal reinforcement,  $f_{yd}$  – design resistance of the longitudinal reinforcement,  $f_{cd}$  – compressive strength of concrete.

The bending beam moment is determined from the following expression

$$M = f_z W_c, \quad (3)$$

where  $f_z$  – design resistance of reinforced concrete under bending, MPa,  $W_c$  – moment resistance of the working section of concrete,  $m^3$ .

The design resistance of concrete under bending is calculated using the following formula

$$f_z = k_z f_{cd}. \quad (4)$$

The parameter  $k_z$  is functionally dependent on the mechanical percentage of reinforcement. From henceforth, the dependence function is simply deduced from the set of equilibrium equations, by the use of true Bernoulli's assumption [9]. This dependence is presented in table 1.

Now we will show how to use the proposed method for the calculation of a combined section. Let us assume that as a result of the calculation of a beam made of the certain concrete grade of size  $b_1 \times d$ , with  $A_{sp}$  reinforcement, we have determined the necessity to increase the dimensions up to  $b \times d$  and reinforcement up to  $A_s$  with the same concrete grade (Fig. 3). It is necessary to define the additional reinforcement in case of reinforcing the beam with another concrete grade.

For the composite beam, we will take on the value of the bending beam moment in such a way:

$$M = M_1 + M_2; f_{cd1} k_z \frac{bd^2}{6} = f_{cd1} k_{z1} \frac{b_1 d^2}{6} + f_{cd2} k_{z2} \frac{b_2 d^2}{6}. \quad (5)$$

Let us conditionally divide the reinforcement of the composite beam in such a way so that:

$$M_1 = M_2; f_{cd1} k_{z1} \frac{b_1 d^2}{6} = f_{cd2} k_{z2} \frac{b_2 d^2}{6}. \quad (6)$$

Then it can be written as:

$$M = 2M_2; M = f_{cd1}k_z \frac{bd^2}{6} = 2f_{cd1}k_{z1} \frac{b_1d^2}{6}. \quad (7)$$

The abovementioned expressions (6) and (7) make it possible to set the required area of reinforcement when reinforcing the beams with another concrete grade.

**Table 1.** Functional relation of the parameters  $k_z=f(\omega)$ .

№	Parameters for the calculation of bending beam elements	
	$k_z$	Mechanical percentage of reinforcement $\omega$
1	0.000	0.00
2	0.568	0.10
3	0.828	0.15
4	1.071	0.20
5	1.299	0.25
6	1.511	0.30
7	1.706	0.35
8	1.885	0.40
9	2.028	0.45
10	2.070	0.50
11	2.140	0.60
12	2.195	0.70
13	2.310	1.00
14	2.476	2.00
15	2.542	3.00

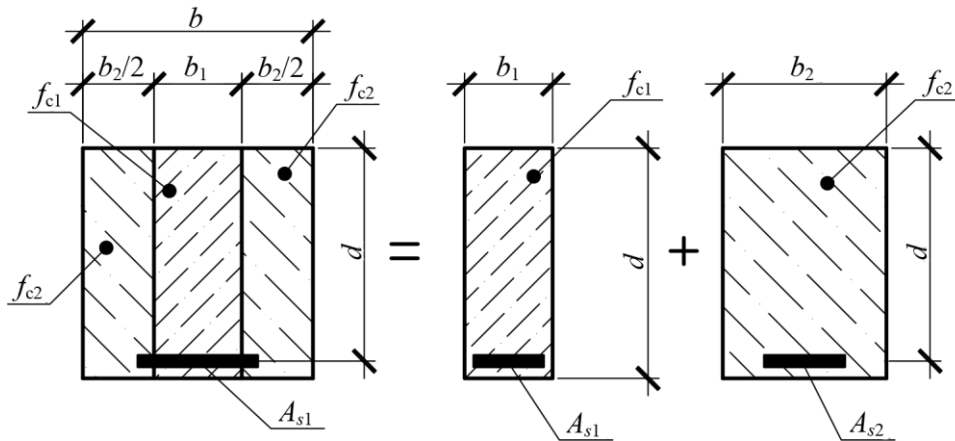

**Figure 3.** Before the calculation of the composite beam.

The necessary reinforcement is determined in the following sequence:

1. Necessary parameters  $k_{z1}$ ,  $k_{z2}$  are determined from the following expression:

$$k_{z1} = \frac{6 \cdot M}{2f_{cd1}b_1d^2}, k_{z2} = \frac{6 \cdot M}{2f_{cd2}b_2d^2}. \quad (8)$$

2. According to table 1 we will find that  $\omega_1=f(k_{z1})$ ,  $\omega_2=f(k_{z2})$ .
3. Now we can define the reference area of reinforcement

$$A_{s1} = \frac{b_1 \cdot d \cdot f_{cd1} \cdot \omega_1}{f_{yd}}, A_{s2} = \frac{b_2 \cdot d \cdot f_{cd2} \cdot \omega_2}{f_{yd}}. \quad (9)$$

4. The full required area of reinforcement can be determined by this formula:

$$A_s = A_{s1} + A_{s2}. \quad (10)$$

5. Additional reinforcement, required for the strengthening, can be defined by this expression:

$$A_{s,d} = A_s - A_{sp}. \quad (11)$$

Let us exemplify the aforecited procedure by strengthening of a continuous beam with a central prop.

It is worth noting that the method of calculated resistances of reinforced concrete is tested on a considerable amount of experimental data of different researchers [12, 13, 14, 15]. Comparison of the flexural strength of the test beams, which is theoretically and experimentally defined in Table 2. In total, 53 experimental beams were tested. Statistical indicators indicate that the proposed methodology is applicable.

**Table 2.** Difference in the theoretically and experimentally determined strength of the cross-sections of the bending elements by different methods.

No	Calculation method	Average value of deviations	Variation coefficient, %
1	AS3600-2001 [16]	0.966	14.93
2	ACI 318R-99 [17]	0.974	16.98
3	CEB-FIP 1990 [18]	1.011	13.73
4	CAN-A23.3-M94 [19] <b>Reference source not found.</b>	0.981	14.46
5	NZS3101-1995 [20]	0.974	14.45
6	Eurocode-2 [4]	0.966	14.93
7	Developed technique [10]	0.961	14.96

### 3. Example of reinforcement of a continuous statically indeterminate reinforced-concrete beam with quadrangular section

Example. Due to the change of production methods, it is necessary to perform the reinforcement of a continuous beam with a central prop with the span of  $l=12$  m (see Fig. 3), which should take the uniform load with the intensity of  $q = 90$  kN/m. The beam with a beam section of  $400 \times 400$  mm ( $d=36$  cm) is made of C20/25 concrete grade ( $f_{cd}=14.5$  MPa), the reinforcement of the beam in the lower zone (beam span armature) is  $2\text{Ø}25$  A500 ( $f_{yd}=415$  MPa),  $A_{s1}=9.82$  cm<sup>2</sup> ( $\rho_f=0.682\%$ ), in the upper zone (bearing bar),  $3\text{Ø}28$  A500 ( $f_{yd}=415$  MPa),  $A_{sc}=18,5$  cm<sup>2</sup>, ( $\rho_f=1.285\%$ ).

Problem solving.

1. Let us predefine the value of the bending beam moment that can be supported by the beam seat and beam span sections of the beam.

$$\omega_l = \frac{\rho_{fl} f_{yd}}{f_{cd}} = \frac{0.68 \cdot 415}{14.5 \cdot 100} = 0.195, \quad \omega_c = \frac{\rho_{fc} f_{yd}}{f_{cd}} = \frac{1.285 \cdot 415}{14.5 \cdot 100} = 0.368.$$

2. According to table 1 we can determine  $k_{z1}(0.195)=1.05$ ,  $k_{z1}(0.368)=1.77$ .

3. The value of the bending beam moment is as follows:

$$M_l = k_{z1} f_{cd} b d^2 / 6 = 1.05 \cdot 14.5 \cdot 40 \cdot 36^2 / 6 \times 10^{-3} = 131.54 \text{ kN}\cdot\text{m},$$

$$M_c = k_{zc} f_{cd} b d^2 / 6 = 1.77 \cdot 14.5 \cdot 40 \cdot 36^2 / 6 \times 10^{-3} = 221.75 \text{ kN}\cdot\text{m}.$$

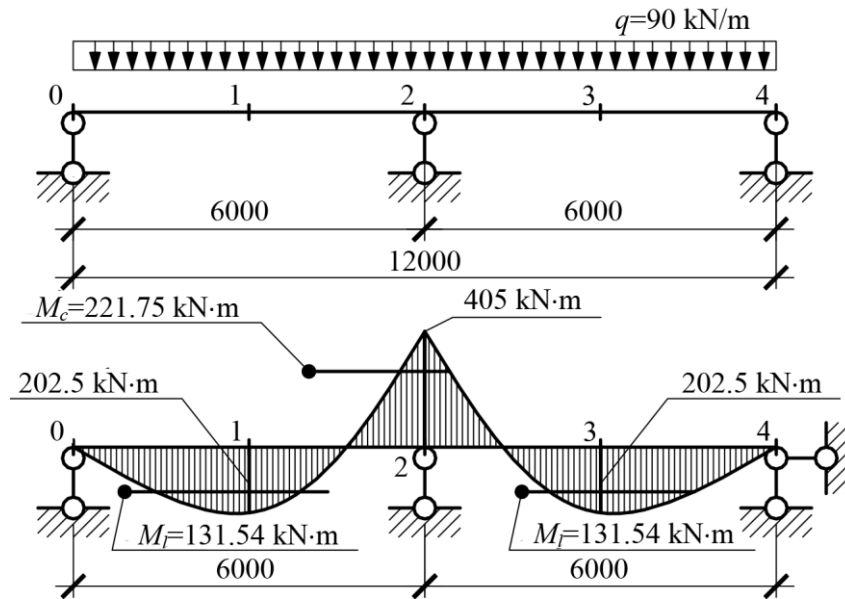

**Figure 4.** Before the calculation of the composite beam.

4. Let us carry out static analysis of the beam under conditions of elastic work of materials with the previously accepted cross section as  $b \times h = 400 \times 400$  mm (see Fig. 4).
5. Previously, at elastic stage, we will preset the desired width of the beam span.
6. Having used the method of design resistances, we can determine the final bending moment diagram (see table 3 and table 4).
7. The aforementioned calculations made it possible to establish the vrai bending moment curve. The validation of its correctness is the defined value of bending deflection equal to zero on the middle beam seat (see table 4).
8. To strengthen the beam, it is necessary to arrange on both sides additional beams with dimensions of  $200 \times 400$  with reinforcement in the lower zone  $2\text{Ø}28$  A500 mm. The concrete reinforcement is C20/25.

**Table 3.** The bending moment diagram and reinforcement over the length of the beam.

№ Beam section	The diameter of the reinforcing steel $d$ and its number	$M$ , kN·m	$b$ , mm	$h$ , mm	The area of reinforcement, mm <sup>2</sup>	The percentage of reinforcement, $\rho_f$
0	2Ø25+4Ø28	0.00	80	40	34.45	1.230
1	2Ø25+4Ø28	215.61	80	40	34.45	1.230
2	2Ø25+4Ø28	301.62	80	40	34.45	1.230
3	2Ø25+4Ø28	258.03	80	40	34.45	1.230
4	2Ø25+4Ø28	84.84	80	40	34.45	1.230
5	3Ø28	-217.96	40	40	18.47	1.319
6	2Ø25+4Ø28	84.84	80	40	34.45	1.230
7	2Ø25+4Ø28	258.03	80	40	34.45	1.230
8	2Ø25+4Ø28	301.62	80	40	34.45	1.230
9	2Ø25+4Ø28	215.61	80	40	34.45	1.230
10	2Ø25+4Ø28	0.00	80	40	34.45	1.230

**Table 4.**Refinement of the bending moment diagram of a continuous beam.

№ Beam section	The distance from p.0, m	$W_c,$ $\text{cm}^3$	Full load			
			$\sigma_{ze},$ MPa	$\Sigma\varepsilon \times 10^4$	$l/r_{mi},$ $\times 10^4 \text{cm}^{-1}$	$a_i \times l/r_{mi},$ $\times 10^4 \text{cm}^{-1}$
0	0.00	16333	0.0	0.0	0.000	0.0000
1	1.20	16333	14.2	18.6	0.491	0.0245
2	2.40	16333	19.4	27.3	0.719	0.0719
3	3.60	16333	15.7	20.9	0.550	0.0825
4	4.80	16333	3.0	2.1	0.056	0.0113
5	6.00	8167	-28.1	-90.3	-2.377	-0.5944
6	7.20	16333	3.0	2.1	0.056	0.0113
7	8.40	16333	15.7	20.9	0.550	0.0825
8	9.60	16333	19.4	27.3	0.719	0.0719
9	10.80	16333	14.2	18.6	0.491	0.0245
10	12.00	16333	0.0	0.0	0.000	0.0000
$f = \Sigma a_i \times l/r_{mi} =$						0.0000

9. To strengthen the beam, it is necessary to arrange on both sides additional beams with dimensions of 200×400 and with reinforcement in the lower zone 2Ø28 A500 mm. The concrete of reinforcement is C20/25.

10. Should the need arise, the method described in the preceding paragraph can be used to determine the required reinforcement when reinforcing the beam with another concrete grade.

11. The overall view of the reinforced beam is presented in Fig. 5.

The design of the proposed continuous reinforced-concrete beam constructions can be done using the developed Internet resource <http://sciencehunter.net/Services/Apps/Concrete>.

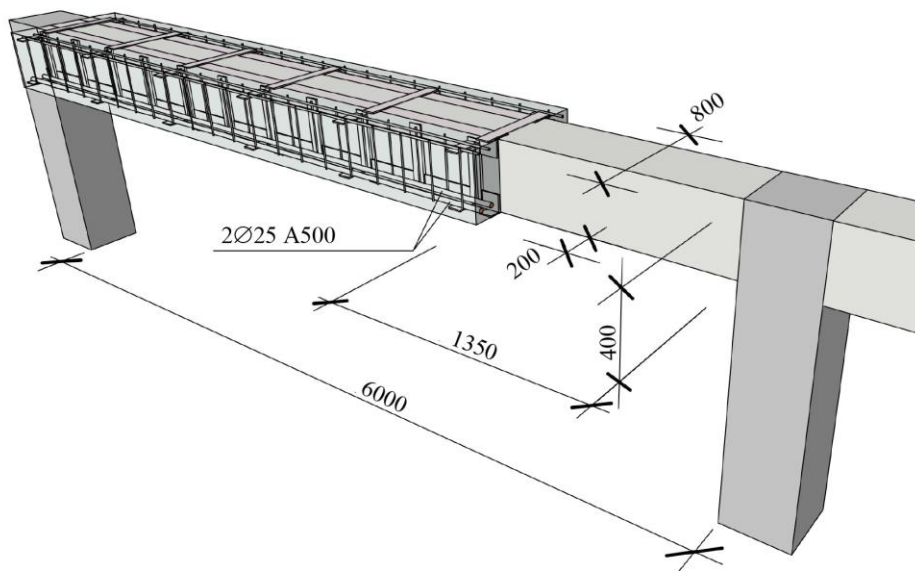

**Figure 5.** The overall view of the reinforced beam.

#### 4. Conclusion

The article presents the method of calculation of continuous beams at their strengthening by increasing the cross-section only in the beam span. It allows you to find effective solutions to strengthen existing



continuous beam systems. Due to the redistribution of forces, the ratio of the beam seat and the beam span of a continuous beam is assorted, and such dimensions of the cross-section of the beams are determined, at which only the bending moment is enlarged, which eliminates the need for the reinforcement of the upper beam seats. This greatly simplifies and cheapens the whole process of reconstruction of such structural systems. This method is distinguished by its simplicity and convenience. In future, we plan to develop the methodology for the calculation of sections of bending composite beam systems.

## References

- [1] Onufriyev N M. 1965 *Strengthening of reinforced concrete structures of industrial buildings and structures* ( Moscow: Strojizdat)
- [2] Wahab N, Soudki K, Topper T. 2014 Experimental Investigation of Bond Fatigue Behavior of Concrete Beams Strengthened with NSM Prestressed CFRP Rods *Journal of composites for construction* **16** 684–692
- [3] Minelli F, Plizzari G, Cairns J. 2009 Flexure and shear behavior class of RC beams strengthened by external reinforcement *Concrete repair, rehabilitation and retrofitting* 377–378
- [4] CEN 2004 EN 1992-1-1: Eurocode 2: Design of concrete structures - Part 1-1: General rules and rules for buildings (Brussels: BSI)
- [5] Wight J.K, MacGregor J.G. 2009 *Reinforced Concrete: mechanics and design* (New Jersey: Upper Saddle River)
- [6] Dem'yanov A, Kolchunov V, Iakovenko I, Kozarez A. 2019 Load Bearing Capacity Calculation of the System “Reinforced Concrete Beam – Deformable Base” under Torsion with Bending *E3S Web of Conferences* **97** 04059
- [7] Andriichuk O.V, Babych E.M. 2017 Strength of Elements with Annular Cross Sections Made of Steel-fiber-Reinforced Concrete Under One-Time Loads *Materials Science* **52** 509 – 513
- [8] Vatulia G, Orel Y, Kovalov M. 2014 Carrying Capacity Definition of Steel-Concrete Beams with External Reinforcement Under the Fire Impact *Applied Mechanics and Materials* **617** 167-170
- [9] Kochkarev D, Azizov T, Galinska T. 2018 Bending deflection reinforced concrete elements determination. *MATEC Web of Conf.* **230** 02012
- [10] Kochkarev D, Galinska T, 2017 Calculation methodology of reinforced concrete elements based on calculated resistance of reinforced concrete *MATEC Web of Conf.* **116** 02020
- [11] Azizov, T., Kochkarev, D., Galinska, T. 2020 Reinforced concrete rod elements stiffness considering concrete nonlinear properties *Lecture Notes in Civil Engineering* **47** 1-6
- [12] Bernardo L. F., Lopes A., 2014 Neutral Axis Depth versus Flexural Ductility in High-Strength Concrete Beams *ASCE Journal of Structural Engineering* **130** 425-459
- [13] Sarkar S., Adwan O., Munday J. 1997 High strength concrete: an investigation of the flexural behavior of high strength RC beams *The Structural Engineer* **75** 115-121
- [14] Pam H. J., Kwan A. K., Islam M. S., 2001 Flexural strength and ductility of reinforced normal- and high-strength concrete beams *Structures & Buildings* **146** 381-389
- [15] Ashour S. A., 2000 Effect of compressive strength and tensile reinforcement ratio on flexural behavior of high-strength concrete beams *Engineering Structures* **22** 413-423
- [16] AS3600-2001 (2001) 2001 Australian Standard for Concrete Structures
- [17] ACI Committee 318 1999 Building Code Requirements for Structural Concrete (ACI 318-99) and Commentary (318R-99)
- [18] CEB/FIP Model MC90 1990 Committee Euro International de Beton
- [19] CAN.3-A23.3-M94 1994 Design of concrete structures for buildings
- [20] NZS3101 1995 Design of Concrete Structures, Standards Association of New Zealand